



Medieval & Early Modern Manuscripts

BOOKBINDING TERMS,
MATERIALS, METHODS,
AND MODELS

Medieval & Early Modern Manuscripts

BOOKBINDING TERMS,
MATERIALS, METHODS,
AND MODELS

*This booklet was compiled by the Special Collections
Conservation Unit of the Preservation Department of Yale
University Library. If you have any comments or questions,
please email Karen Jutzi at karen.jutzi@yale.edu.*

A NOTE ON DATES & TERMINOLOGY:

The terms 'Carolingian', 'Romanesque', and 'Gothic' are used in this booklet to describe a method of board attachment as recognized by J.A. Szirmai in *The Archaeology of Medieval Bookbinding* (Aldershot: Ashgate, 1999), and are often used by others to describe medieval binding structures.

While a convenient method of categorization, using the name of the historical period to describe a style of binding can be misleading. Many other styles of binding existed concurrently; it should not be assumed that all bindings of a certain historical period were bound the same way. Furthermore, changes in bookbinding did not happen overnight. Methods co-existed; styles overlapped; older structures continued to be used well into the next historical period.

Many thanks to Professor Nicholas Pickwoad, University College, London, for his helpful comments, suggestions, and corrections on terminology.

Table of Contents

MATERIALS OF MEDIEVAL & EARLY MODERN BOOKBINDING

Wood	8
Leather	9
Alum-tawed skin	10
Parchment & vellum	11

TERMINOLOGY

Parts of a medieval book	14
Outside structure	15
Inside structure	16
Bindery tools & equipment	17
Board Attachment Styles	18
Sewing & Supports	20

EARLY MEDIEVAL STIFF-BOARD BINDINGS

Characteristics	22
Binding Steps	23
Binding Model	24

MONASTIC & ROMANESQUE STIFF-BOARD BINDINGS

Characteristics	26
Binding Steps	27
MS 4	28

LATE MEDIEVAL STIFF-BOARD BINDINGS

Characteristics	30
Binding Steps	31
MS 84 — girdle book	33

LIMP BINDINGS

MS 610 — limp parchment (laced case)	36
MS 649 — limp parchment (longstitch)	37

BIBLIOGRAPHY

39

Materials

Wood

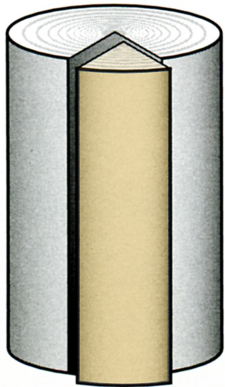

Quarter-cut

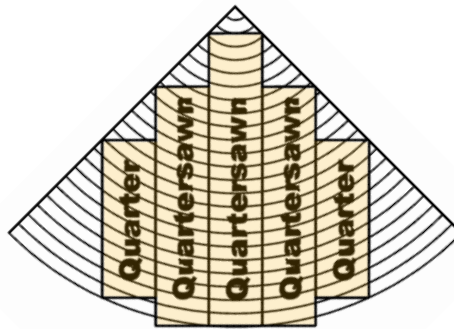

Planks cut radially

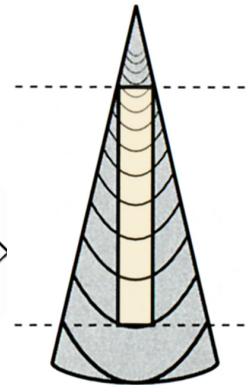

Quartered
Wood for book cover

Boards for bookbinding were traditionally quartered (sawn, cleft, or split). The growth rings in quartered wood run mostly perpendicular to the surface of the board, which makes the wood less likely to warp or shrink from moisture or changes in humidity.

The process was to cut, cleft or split the log lengthwise into four wedged-shaped pieces. The wedges were then tipped on their points and the boards were sawn, cleft or split along the axis (see illustration above).

In England, the predominant wood used in bookbinding was oak, although beech was also used. Beech was common in Italy and Germany. Oak and beech were the most common woods used on the Continent, but birch, lime, chestnut, maple, poplar, plane, pinewood and walnut have all been used at one time or another (Szirmai 1999, 103, 151, 216).

Leather

The process of making leather is called tanning. The word derives from the use of tannins—from the Medieval Latin *tannare* (“tan, dye, a tawny color”) and *tannum* (“crushed oak bark”), probably from the Celtic word *tann* (“oak tree”). Tannins were traditionally derived from crushed oak bark.

The skin was soaked in water, then placed in a solution of lime. This loosened the hair and other bits, which could then be scraped off over a beam of wood with a blunt knife. The liming process also swelled and loosened the fiber structure (Vest 2000, 16-17). The skin side was scraped to clean it and level it out. The grain side was scraped with a knife to remove any remaining hair, lime, grease or dirt, then trimmed of unwanted pieces. The scraping process was called “scudding.”

The skin might then be “bated” (immersed in warm water and dog dung) or “puered” (which used bird droppings instead of dog dung), which, after another round of scudding, produced a very smooth grain. “Bran drenching” was sometimes used instead of bating/puering: the skin was soaked in a warm solution of barley or rye and stale beer or urine, which neutralized any remaining lime in addition to softening the skin (Burns 2011).

After another washing, the hide could either be tanned, tawed, or made into parchment.

The tanning process began by soaking the hides in the tanning solution (in England, crushed oak bark and water). This was done in pits. The skins were constantly moved around in the pits to ensure the tannins (and thus the color) spread evenly. The hides would then be layered with ground oak bark, the pits were filled with a weak tanning solution, and the hides were left for up to a year (Burns).

At the end of the tanning process, the hides were rinsed, smoothed, and left in a dark place to dry slowly. The leather was then staked (the flesh side was stretched and pulled over a blunt metal or wooden edge—see *Alum-tawed skin* illustration), shaved to the desired thickness, and greases were applied to make it supple.



Scudding

Note bindings in cupboard, and the tub used to soak skins.

Die Hausbücher der Nürnberger
Zwölfbrüderstiftungen.

Amb. 317b.2° Folio 77 recto (Mendel II)
Stadtbibliothek Nürnberg

Alum-tawed skin

Also called white-tawed or whittawed skin.

The process of tawing skin began with the same steps as tanning leather or making parchment: the skin was soaked in lime, scraped over a beam of wood with a blunt knife, bated or puered or brandrenched, and washed again. The skin was now ready to be tawed.

A tawing paste made with water, alum, salt, egg yolk, and flour was mechanically worked into the wet, dehaired pelt. Once the paste solution was absorbed by the skin, it was hung up to dry for several weeks (this was called “crusting”).

Once dry, the skin was stiff and inflexible. The final step was staking (as portrayed on the right), which softened the skin and left it brilliantly white and stretchy.



Staking

Note skins hung up to dry in background.

Die Hausbücher der Nürnberger
Zwölfbrüderstiftungen

Amb. 317b.2° (Mendel II)
Stadtbibliothek Nürnberg

Parchment & Vellum

The terms parchment & vellum are often used interchangeably, but historically parchment was made from split sheepskin, while vellum (from the Old French *velin*, from *vel*, *veel* “calf”) was made from calfskin.

The same initial steps of tanning and tawing were followed, to de-hair and clean the skin. After a final washing, the skin was stretched on a frame and scraped with a crescent-shaped knife called a *lunarium* to remove additional flesh. The stretched skin was left to dry, after which it was thinned further by sanding.

Parchment and vellum are very sensitive to moisture and fluctuations in humidity levels. The clasps and wooden boards of medieval bindings served to compress and restrain the parchment during these fluctuations.



Scraping

Die Hausbücher der Nürnberger
Zwölfbrüderstiftungen.

Amb. 317.2° Folio 34 verso (Mendel I)
Stadtbibliothek Nürnberg

Terminology

Parts of a medieval book

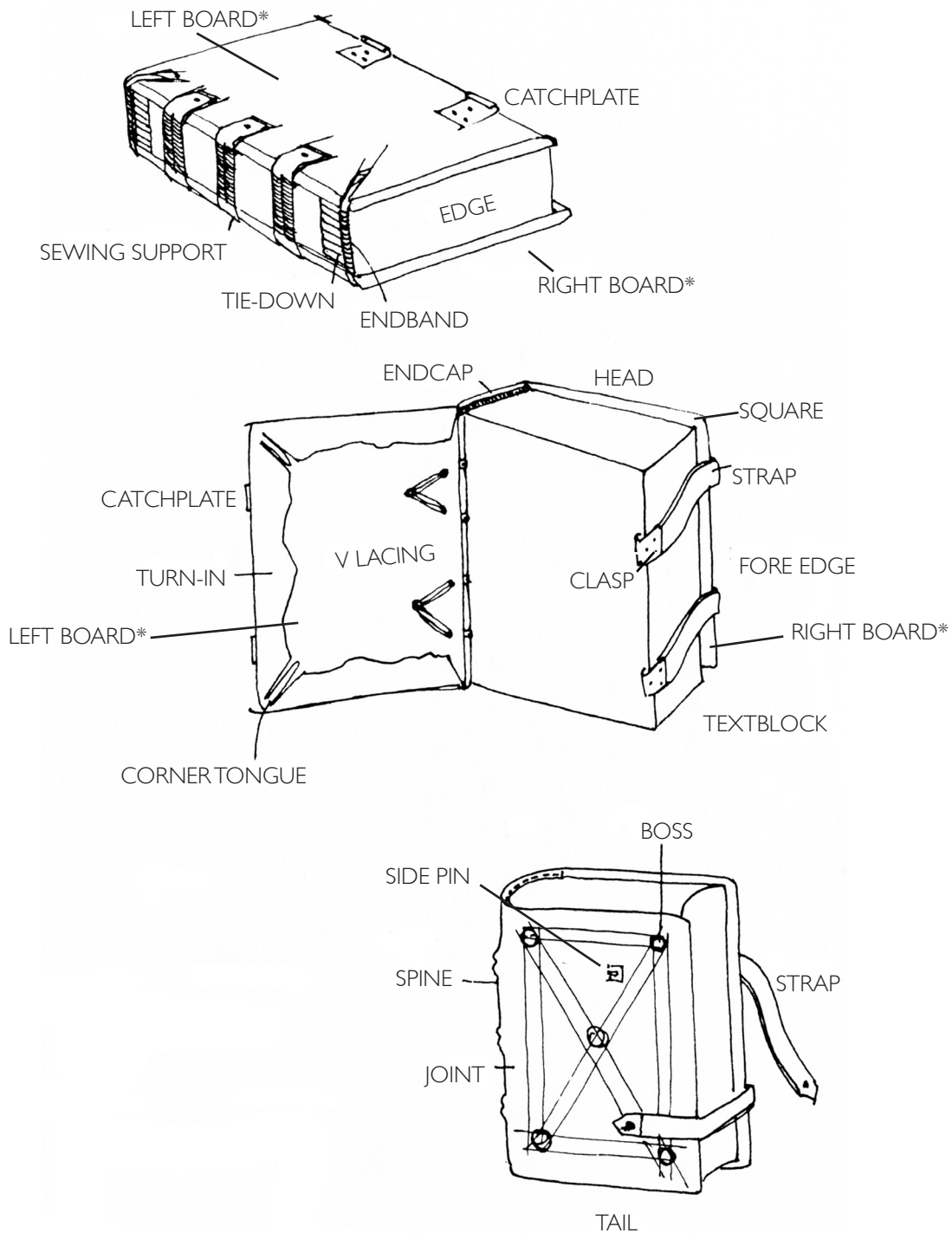

*'Left' and 'right' instead of upper/lower or front/back are the terms Nicholas Pickwoad recommends (University of the Arts, London; Ligatus.org.uk). These terms can be applied to books in both left-to-right and right-to-left written languages without confusion.

Drawings by Jane Greenfield from *Catalogue of Medieval and Renaissance Manuscripts in the Beinecke Rare Book and Manuscript Library, Yale University, Volume I: MSS 1-250*, by Barbara Shailor.

Outside structure



*Unless it can be determined which tool was actually used (e.g., creaser, straight-line pallet, fillet), Nicholas Pickwoad recommends the use of a more generic description such as “3-line tool” (email to the author, 21 October 2014).

Inside structure

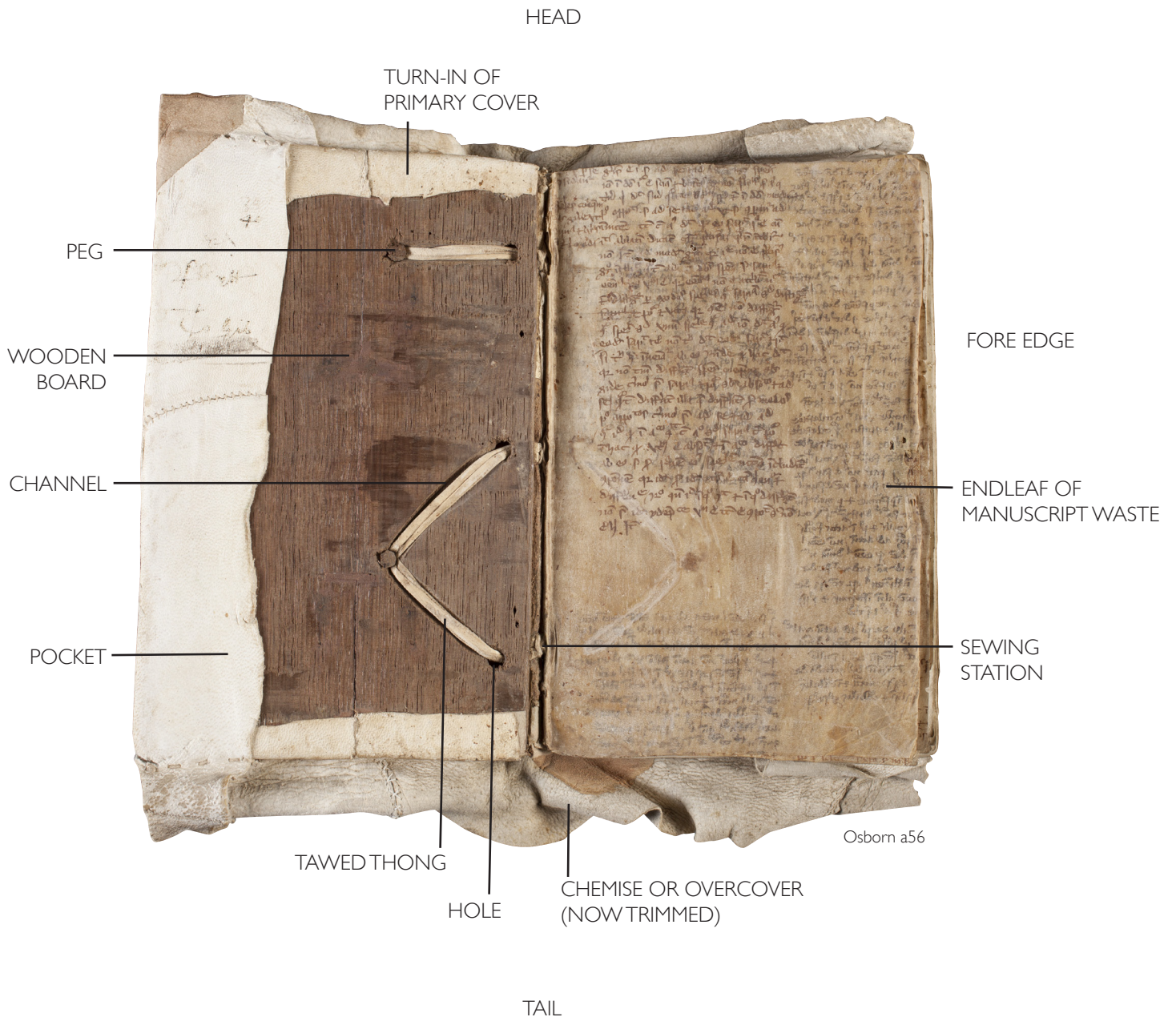

Bindery tools

FROM THE BOOK OF TRADES

BY JOST AMMAN & HANS SACHS (1568)

Though a depiction of a Renaissance bindery, many of these tools were also used in the Middle Ages.

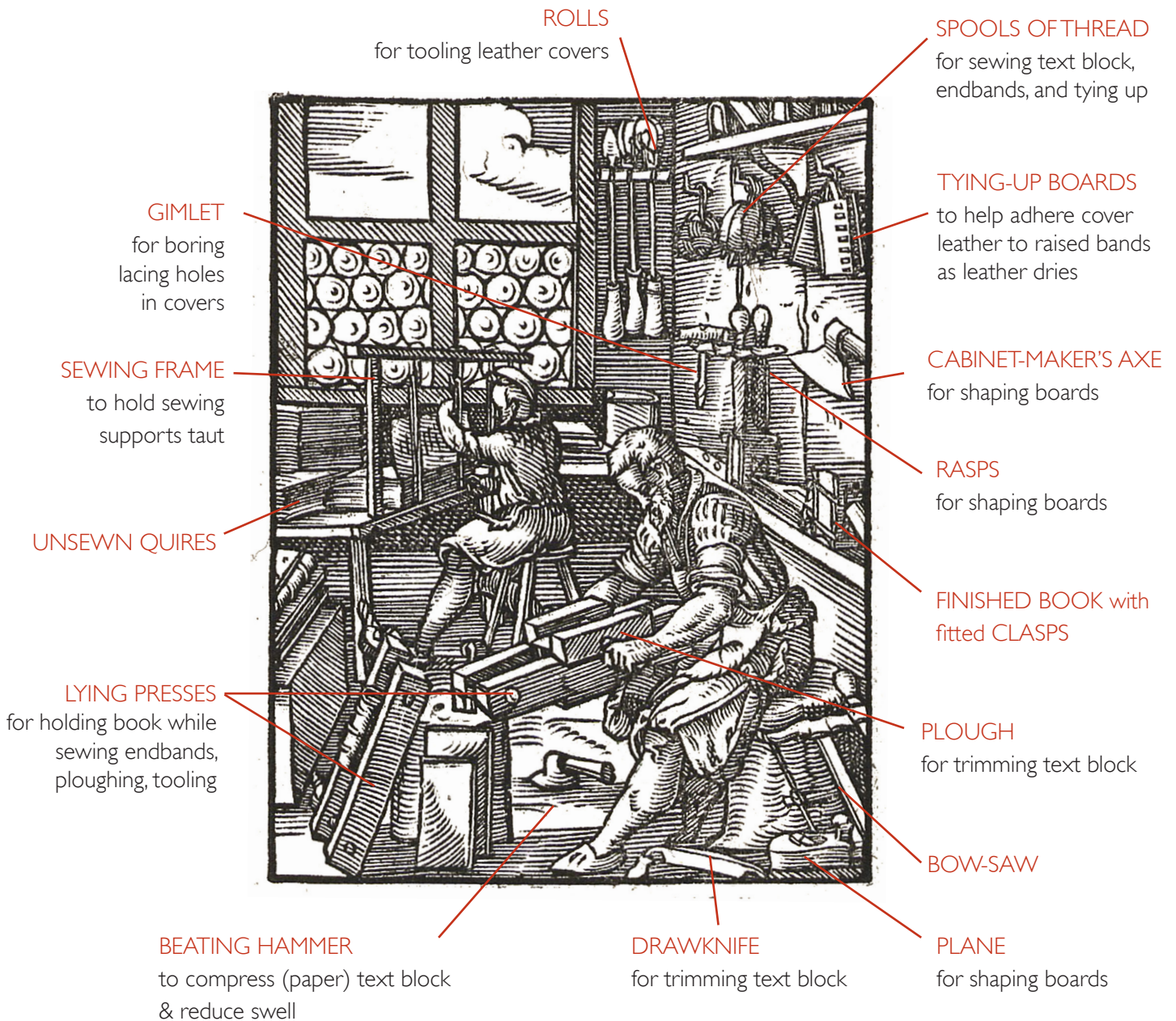

Board Attachment Styles

There are three major stiff-board attachment styles common in the Middle Ages, roughly correlating to the early, middle and late medieval periods.

Early medieval bindings with wooden boards are often referred to as Carolingian. They can be identified by sewing supports of thin, vegetable-fiber cords, which enter the edges of a thick, square board and are looped through angular channels. The boards would most likely have been covered by a tawed skin, which often extended into tabs on either end of the flat spine. The endbands were sewn through the tabs, strengthening the overall binding structure.

Romanesque bindings are easily identifiable by their thick, squarish wooden boards, flat spine, thick alum-tawed supports (typically flat straps, with a slit down the middle), and entry of the supports through the edge of the board. Monastic Romanesque bindings also would have had endband tabs, were usually covered in tawed skin, and likely would have had a chemise or overcover—a secondary cover which extended past the boards to protect the edges of the text block (see p. 16). There was also second type of Romanesque binding with similar sewing supports and lacing paths, but covered in tanned skin and blind-tooled (see MS 4 on page 28); these were probably done by lay binders outside the monastery.

Gothic (late medieval) bindings are identified by their shaped boards (often covered in tanned skin), rounded spine, an increased number of visible, raised bands, and metal fastenings and furnishings. These bindings were sewn on supports of alum-tawed skin or on vegetable-fiber cords (See *Sewing & Supports*, p. 20, for examples). In Gothic bindings, the supports were laced through the exterior face of the board, not the edge. This tended to pull the spine into a natural round, which was often made more pronounced with backing hammers and reinforced with hide glue and linings on the spine.

CAROLINGIAN Type I* (EARLY)

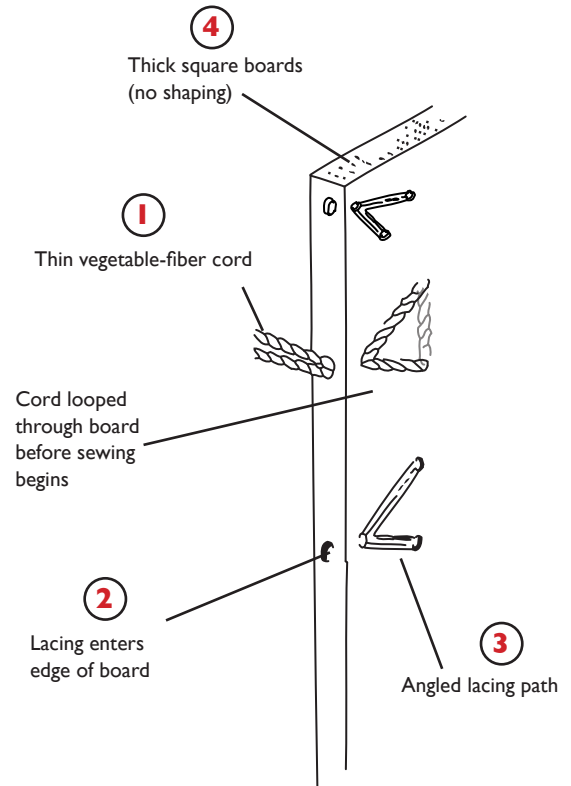

①	SUPPORT	THIN VEG. FIBER CORD
②	ENTRY	EDGE
③	PATH	ANGLED
④	BOARD	THICK; NO SHAPING

**this is a 'Type I' style board attachment, See Szirmai 111-113 for Types II-IV.*

ROMANESQUE (MIDDLE)

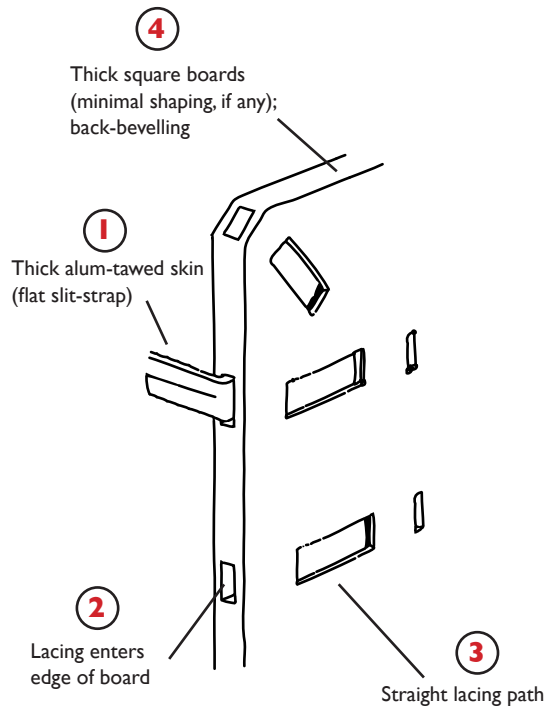

GOTHIC (LATE)

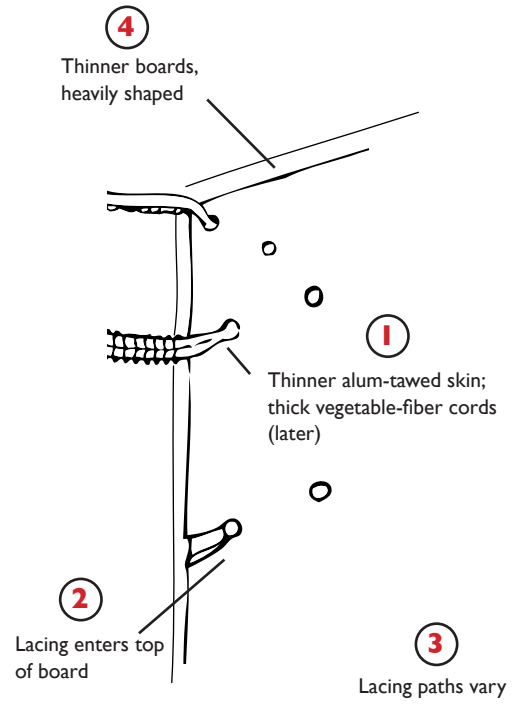

TAWED SKIN

TAWED SKIN OR VEG. FIBER CORD

EDGE

SURFACE

STRAIGHT

VARIED

THICK; MINIMAL SHAPING; BACK-CORNERED

THINNER; SHAPED

Sewing e3 Supports

MOST COMMONLY USED FOR MEDIEVAL & EARLY MODERN BINDINGS

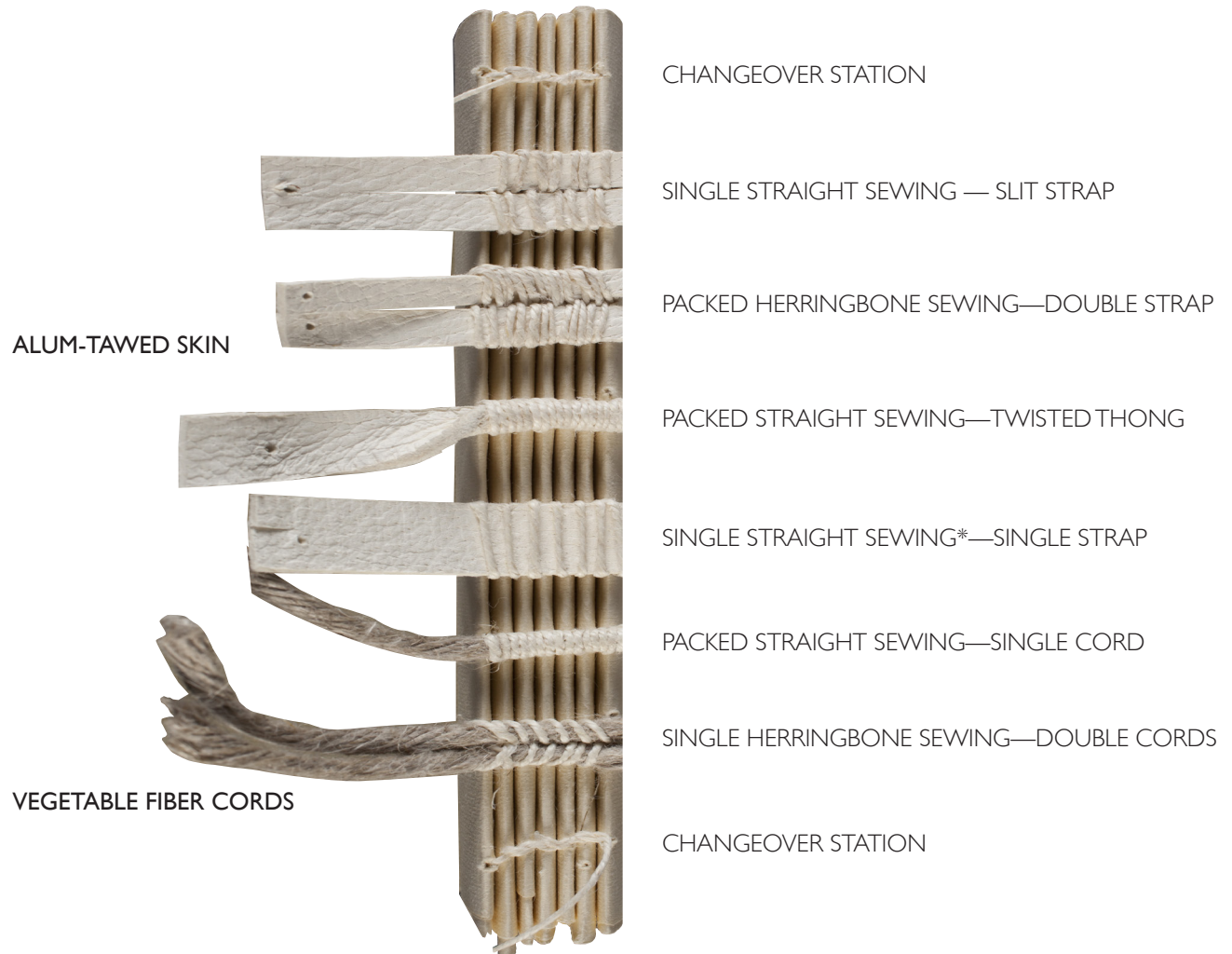

*1-hole station, with thread wrapping around the support. Flat supports like these were more commonly sewn on 2-hole stations, where the thread emerges from the quire, crosses the support, and re-enters the quire through a second hole.

ca. 800-900

Carolingian / Anglo-Saxon

Characteristics

WESTERN MEDIEVAL STIFF-BOARD BINDINGS CA. 800-900

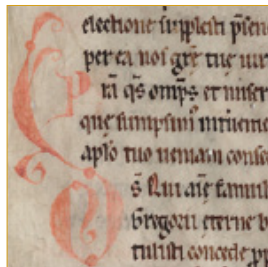

MS 481.108 folio 1R

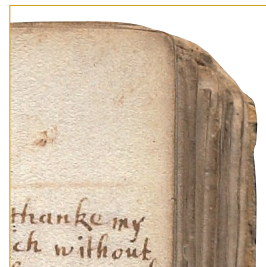

Beinecke MS 331

TEXT BLOCK

Parchment

Flush with boards



Beinecke MS 224



Marston MS 243

SUPPORTS / SEWING

Thin, double cords of vegetable fiber (flax, hemp)

Raised

Herringbone pattern



Beinecke MS 393

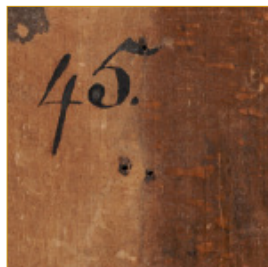

Beinecke MS 688



Beinecke MS 393

BOARDS

Thick

Predominantly oak (also beech, poplar)

Little to no shaping

Same size as text block

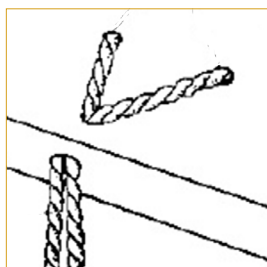

Szirmai Archaeology, 105



Beinecke MS 84

LACING

Through edge of boards

Upper board laced before sewing

Flat spine (not convex)

Note: The manuscripts pictured are used for illustration purposes and may not date from time period indicated.

Binding steps

BASED ON SZIRMAI'S STUDY OF THE BINDINGS AT ST. GALL

1. **Prepare boards first:** determine placement of sewing stations; make tunnels and channels to attach sewing supports; chisel recesses for fastenings.
2. **Lace through** vegetable-fiber supports to upper board.
3. **Prepare quires for sewing** by cutting 3-6mm slits into spine folds at predetermined sewing stations (slits were common on insular manuscripts; pierced holes common on continental—often French).
4. **Sew quires to supports**, using a herringbone pattern, beginning with first quire.
5. After last quire is sewn, **lace supports through lower board** and secure by twisting and pegging; trim excess with chisel.
6. Reinforce board attachment with **board stabilizers*** (generally first leaf of the first quire & last leaf of last quire).
7. **Trim edges of text block** flush with boards (probably using a drawknife).
8. **Sew endbands** through tab lining.
9. **Construct strap(s)** using same material as book covering.
10. Dampen and **paste out covering leather** (commonly chamois / reversed alum-awed); **adhere to boards** (usually not spine); turn in. Turn-ins will be on top of pastedowns (or 'board stabilizers')—a characteristic of Carolingian bindings.
11. **Sew perimeter of tab endbands** to adhere tab lining to cover tab.
12. **Cut slit for strap** and feed strap through.
13. **Attach strap(s)** to recess(es) in cover with iron or brass nails through thickness of board.
14. **Attach pin(s)** to edge of lower board.

*"Pasting the outermost endleaf/guard to the boards before covering to stabilize the boards on the joints has led Chris [Clarkson] and I to call them 'board stabilisers'." Nicholas Pickwoad, email to K. Jutzi, 21 October 2014.

ca. 1000-1250

Romanesque / Norman / Monastic

Characteristics

WESTERN MEDIEVAL STIFF-BOARD BINDINGS CA. 1000-1250

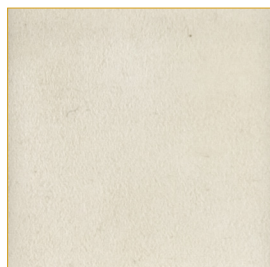

Beinecke MS 481

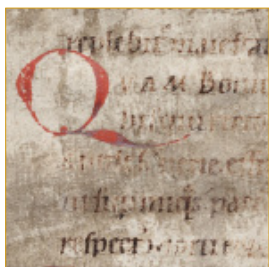

Beinecke MS 688



Marston MS 93



Marston MS 262



Beinecke MS 393

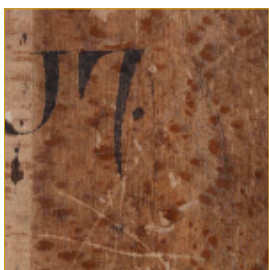

Beinecke MS 873



Beinecke MS 393

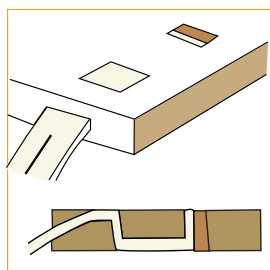

Beinecke MS 393

TEXT BLOCK

Parchment (thin, sheep)
Flush with boards

SUPPORTS / SEWING

Thick alum-tawed slit straps
Herringbone, straight or packed

BOARDS

Thick
Oak, beech, or poplar
Minimal or no shaping
Same size as text block—
no squares

LACING

Through edge of boards
Flat spine (not convex)
Straight lacing path

Note: The manuscripts pictured are used for illustration purposes and may not date from time period indicated.

Binding steps

BASED ON STUDIES BY J.A. SZIRMAI

1. Determine placement of sewing stations; **pierce quires** with awl or sewing needle, or cut slits with knife or chisel.
2. **Sew onto alum-tawed straps** (usually slit). Sewing could be herringbone pattern (typical for English Monastic bindings), single straight sewing, or packed straight sewing.
3. **Prepare wooden boards** by drilling tunnels through spine edge and chiselling/carving out tunnels and channels for sewing supports; back-corner to accommodate endbands; shape boards (optional).
4. **Lace ends of sewing supports** through boards; secure with wooden pegs and trim off/sand excess.
5. **Trim edges of text block** flush with boards (probably using a drawknife or chisel).
6. **Add tab linings** for endbands (for Monastic bindings).
7. **Work endbands** through tab linings. Endbands could be herringbone or straight sewing on double supports, possibly with colored thread (often blue); plain wound; or plain wound with secondary sewing in colored linen or silk.
8. **Line spine** (often with “chamois” leather / alum-tawed): full lining; patch linings between sewing supports; lining extending onto inside or outside of boards.
9. **Cover boards** with either alum-tawed skin (English Monastic bindings) or tanned brown leather (lay binders) using starch paste.
10. **Paste down parchment endleaves** over turn-ins. Endleaf construction could vary, but the majority were sewn with the textblock and were often the first and last leaves.
11. If covered with **tanned leather, tool in blind**.
12. *Optional but likely for Monastic-style bindings:* Add secondary cover (chemise or overcover).
13. **Add fastenings and furnishings**. Long-strap fastenings are predominant, but could also be Carolingian-style edge-and-pin fastening).

MS 4

LATE 15TH CENTURY

St. Antonius, Confessionale

154 x 103 (95 x 69) mm

Written in Italy, end of 15th century. Original sewing on three tawed, slit straps, stained pink, laced through tunnels in the thickness of wooden boards into rectangular channels on the outer face. Twisted, tawed cores of plain, wound endbands laid in channels. All supports pegged and gypsum [?] used to fill in around them. Endband linings in brown calf. Covered in brown calf, blind-tooled with a rope interlace panel border. Tongued mitre corner turn-ins. Two catchplates on right board, stubs of straps on left. Boards worm-eaten and detached and most of the cover wanting. Minor repairs to endleaves and headband made ca. 1976.

(Description from *Catalogue of Medieval and Renaissance Manuscripts in the Beinecke Rare Book and Manuscript Library, Yale University, Volume I: MSS 1-250*, by Barbara Shailor)

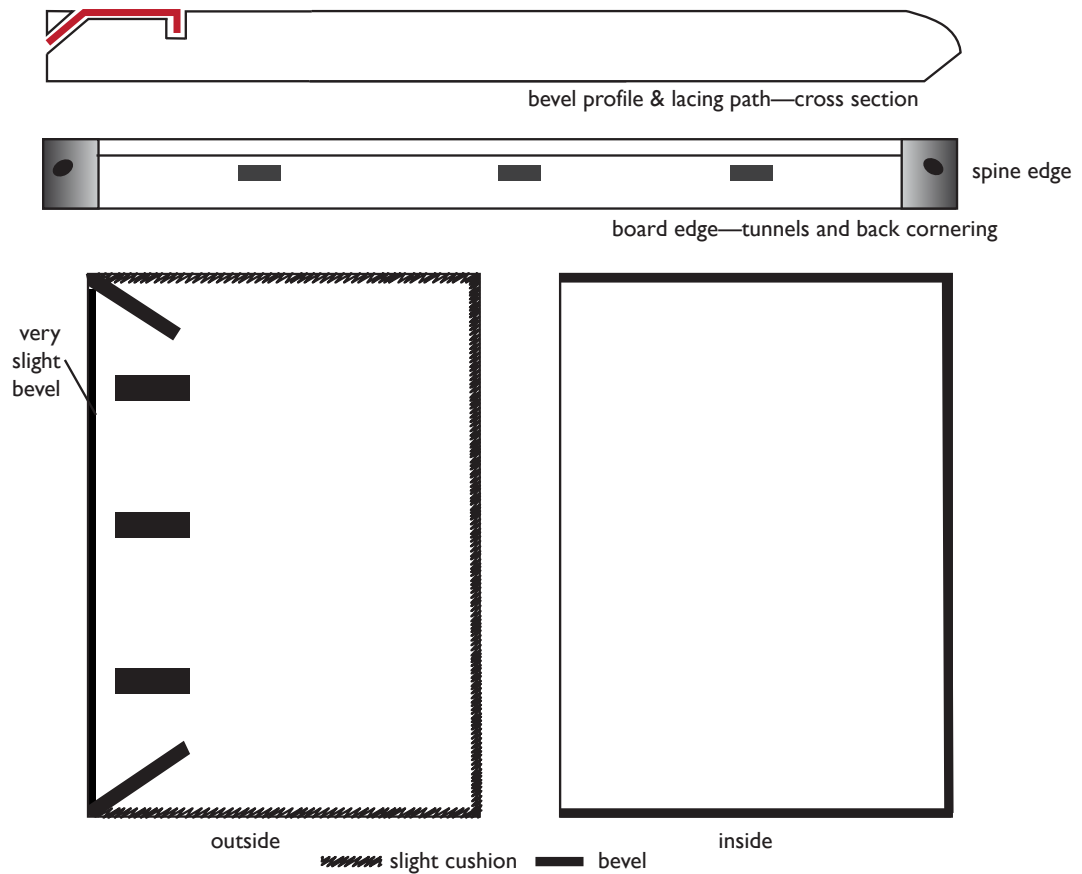

ca. 1150-1420

Gothic / Late Medieval

Characteristics

CA. 1150-1420

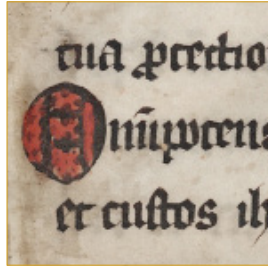

Beinecke MS 481.122 folio 1R



Beinecke MS 287 folio 3r

TEXT BLOCK

Parchment, parchment & paper, or (later) all paper
Smaller than boards



Marston MS 93

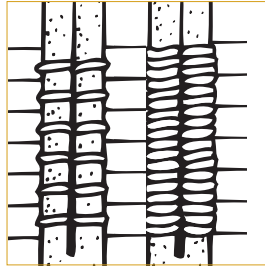

SUPPORTS / SEWING

Alum-tawed skin,; vegetable-fiber cords (later)
Straight or packed sewing (often "packed" due to thicker sections)



Beinecke MS 710

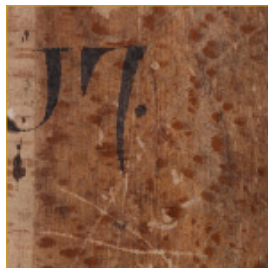

Beinecke MS 873



Beinecke MS 287 folio 24R

BOARDS

Thick
Oak (beech, poplar)
Lots of shaping
Larger than text block (has squares)

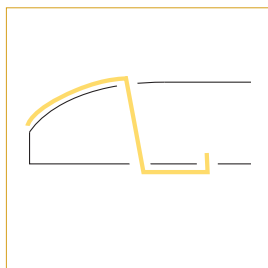

Beinecke MS 417

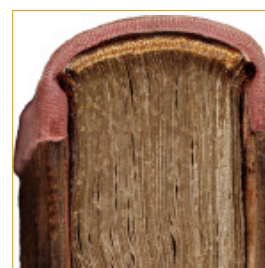

Beinecke MS 287

LACING

Through exterior face of boards
Rounded spine

Note: The manuscripts pictured are used for illustration purposes and may not date from time period indicated.

Binding steps

BASED ON STUDIES BY J.A. SZIRMAI

1. If paper was used for quires, reinforce the inner centerfolds with parchment sewing guards (*optional—some binders were initially suspicious of paper, believing it lacked strength and would need reinforcement to be sewn*).
2. **Add endleaves** to textblock. Endleaves are almost always parchment; often manuscript waste. Endleaf attachment varies widely.
3. Decide number of sewing supports and placement of sewing stations; **cut or pierce holes for sewing**.
4. **Decide material of sewing supports**: vegetable fiber cords (single or double) or alum-tawed skin (slit strap; intertwisted slit thong; double strap, loosely or tightly twisted single or double thongs).
5. **Sew quires onto supports**—either herringbone (single or packed), straight, or packed. To save time, endbands can be sewn along with quires (integral sewing).
6. **Consolidate spine** with adhesive (hide glue).

Optional: do not glue up spine.

7. **Round spine with backing hammer** if text block is paper (*to compensate for “swelling” of text block from sewing thread. Parchment’s tendency to cockle cancelled out any swelling from sewing thread, so mechanical rounding with hammer was generally not needed*).
8. **Line spine** with parchment, leather, or reversed alum-tawed skin (patch; transverse; slotted; comb...).

Optional: do not line spine.

9. **Trim edges of textblock** (with drawknife; with plough after first quarter of 16th century).

Optional but not common: decorate edges (paint; stain; gild; gauffer).

10. If not sewn integrally, **work endbands** now. Endbands varied: plain wound; saddlestitch; plain wound with additional sewing in colored linen or silk; braided leather.
11. **Prepare boards**: shape and prepare tunnels & channels for lacing and clasps. Board edge shapes varied widely, as did lacing path patterns.
12. **Lace ends of sewing supports into boards**; peg.
13. **Cover boards** in dampened leather (usually tanned or tawed) with starch paste or combination of paste/animal hide glue. Could also be covered in precious textiles, primarily or secondarily (see below).
14. **“Tie up” raised bands with cords** to adhere damp leather firmly around raised supports while drying.

Optional:

- Stain alum-tawed leather, either before or after covering (sap green, saffron, brazilwood, iron-gall ink, verdigris...).
- Decorate/tool tanned leather.
- Add overcover (leather overcover; textile chemise; girdle book; overback).

15. **Attach fastenings** (long-strap; hook-clasp) and any furnishings: corner pieces, center pieces, bosses, shoes, heels, title windows (*fenestra*), edge strips, skids, chains.

MS 84

GIRDLE BOOK (15TH CENTURY)

Boethius: *De consolatione philosophiae*.

100 x 80 (68 x 41) mm

Binding circa 15th century, possibly German or Dutch. Although early, it is not the original binding. Resewn on three narrow, tawed slit-straps. The supports are laced into channels in beech boards, the pattern reversed; one horizontal above one V lacing on the upper board and a V above a horizontal on the lower. The supports are pegged. The secondary cover of tawed skin, now grey, is sewn to a tawed, pink, primary cover around the outer edges of the boards. The secondary cover extends about 130 mm to a Turk's head knot at the tail, about 25 mm at the head, and has an overlap of about 50 mm on the left board. The edges of the secondary cover are turned in and hemmed. The book hung upside down when attached to the girdle by having the knot slipped under it, but was right side up when picked up (still attached to the girdle) to be read. A strap-and-pin fastening, the pin on the right board, consists of a thick, brown leather strap nailed to the left board and tacketed to the cover with the leather strap ending in an anthropomorphic brass clasp, the head of which catches on the pin.

(Description from *Catalogue of Medieval and Renaissance Manuscripts in the Beinecke Rare Book and Manuscript Library, Yale University, Volume I: MSS 1-250*, by Barbara Shailor)



outer left

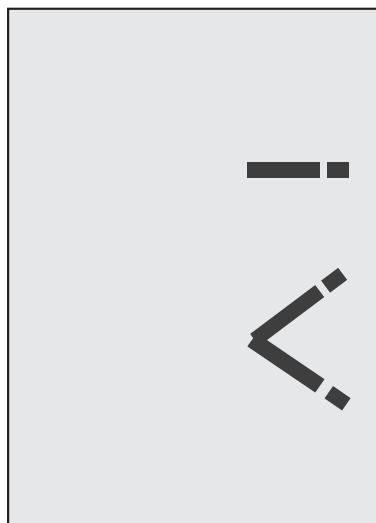

inner left

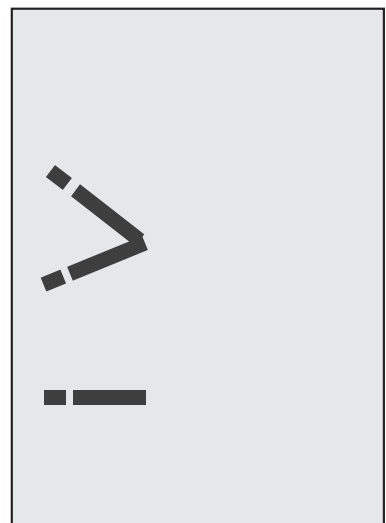

inner right

Limp bindings

MS 610

EARLY-MODERN LIMP PARCHMENT LACED-CASE (1571)

Bouche of Courte.

305 x 205 mm

Limp parchment with remains of leather ties. Manuscript on paper.

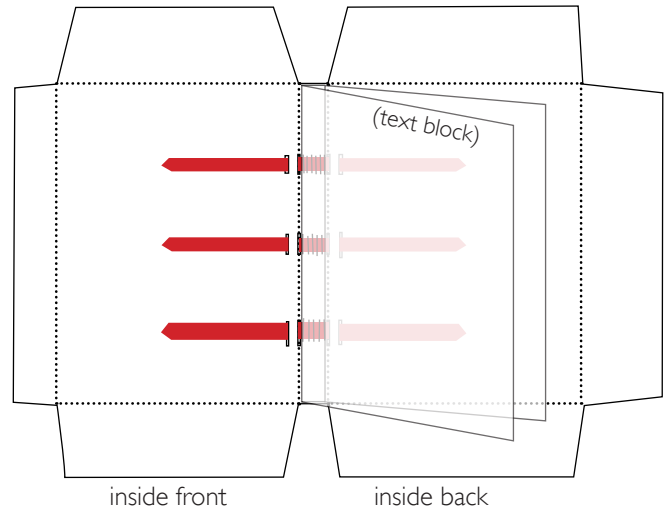
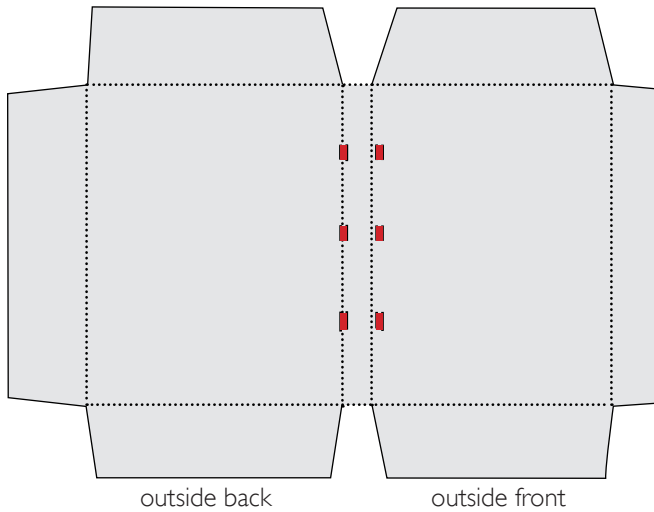

..... fold
— alum-tawed slips (not to scale—width of slips enlarged for clarity)



MS 649

LIMP PARCHMENT LONGSTITCH (1377)

*Sermons of Graeculus O.F.M. and
Conradus de Waldhausen Can Reg.*

220 x 150 mm

Damaged original limp parchment longstitch binding with flap, made from several pieces of parchment laced together by means of parchment strips. The textblock is paper, and comprised of 12 quires, sewn as a longstitch through the parchment cover and two spine stiffeners of tanned hide. The hide is pierced with 3 holes, with 4 quires sharing one hole. The primary sewing is reinforced with a secondary protective weaving of thread.

(Description from *Catalogue of Medieval and Renaissance Manuscripts in the Beinecke Rare Book and Manuscript Library, Yale University, Volume 1: MSS 1-250*, by Barbara Shailor)

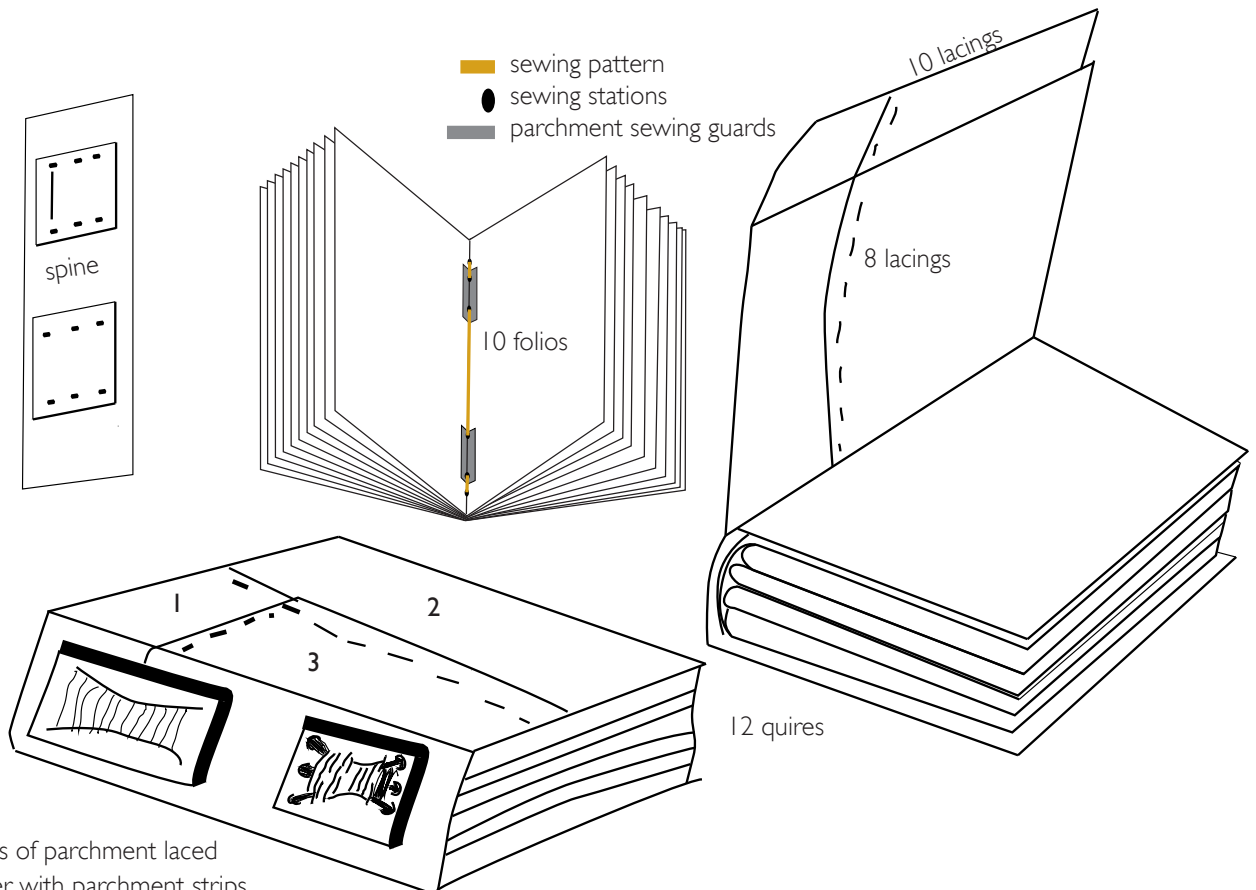

Bibliography

GENERAL

- Cambridge Histories Online. *Cambridge History of the Book in Britain Volumes I-III*. Cambridge University Press, 2012. AVAILABLE ONLINE AT: <http://www.universitypublishingonline.org/cambridge/histories>
- Gillespie, Alexandra and Daniel Wakelin, Ed. *The Production of Books in England 1350–1500*. New York: Cambridge University Press, 2011.
- Needham, Paul. *Twelve Centuries of Bookbindings: 400-1600*. New York: Oxford University Press, 1979.
- Roberts, Jane and Pamela Robinson. *The History of the Book in the West: 400 AD-1455, Volume 1*. Farnham: Ashgate, 2011.

TERMINOLOGY

- Gnirrep, W.K., J.P. Gumbert, and J.A. Szirmai. *Kneep e Binding: een terminologie voor de beschrijving van de constructies van oude boekbanden*. The Hague: CIP-Gegevens Koninklijke Bibliotheek, 1993
- PDF AVAILABLE ONLINE AT: www.kb.nl/expertise/conservering/kneep-en-binding-digitale-versie
- Roberts, Matt T. and Don Etherington. *Bookbinding and the Conservation of Books, a dictionary of descriptive terminology*. Washington: Library of Congress, 1982. (While not limited to the medieval period, still a useful reference.) AVAILABLE ONLINE AT: www.cool.conservation-us.org/don/don.html

MATERIALS

- Burns, Claire. "The Tanning Industry of Medieval Britain" in *The Collegiate Journal of Anthropology, Vol. 1*. Friday, June 15, 2012. <http://anthrojournal.com/issue/october-2011/article/the-tanning-industry-of-medieval-britain>
- Clarkson, Christopher. "Rediscovering Parchment: The Nature of the Beast," *The Paper Conservator*, 16:1, 5-2, 1992.
- Federici, Carlo, Anna di Majo, and Marco Palma. "The Determination of Animal Species Used in Medieval Parchment Making: Non-Destructive Identification Techniques" in *Roger Powell: The Compleat Binder, Liber Amicorum, Bibliologia 14*. ed. J.L. Sharpe. Turnhout: Brepols, 1996, 146-153.
- Gameson, Richard. "The material fabric of early British books" in *The Cambridge History of the Book in Britain Volume II: 1100-1400*, Cambridge University Press, 2012, 13-93.
- Reed, R. *Ancient Skins, Parchments and Leathers*, Cambridge University Press, 2012, 13-93.
- Vest, Marie. "The production and use of alum-tawed leather in the Middle Ages and later" in *Care and conservation of manuscripts 5, Proceedings of the fifth international seminar held at the University of Copenhagen 19th-20th April 1999*. ed. by Gillian Fellows-Jensen and Peter Springborg. Copenhagen: The Royal Library, 2000, 16-20.

BOOKBINDING STRUCTURES & TECHNIQUES

GENERAL

Frost, Gary. "Mobility and Function in the Codex Bookbinding" in *Roger Powell: The Compleat Binder; Liber Amicorum, Bibliologia 14*. ed. J.L. Sharpe. Turnhout: Brepols, 1996, 92-100.

Middleton, Bernard. *A History of English Craft Bookbinding Technique*. New York & London: Hafner Publishing Company, 1978.

Szirmai, J.A. *The Archaeology of Medieval Bookbinding*. Aldershot: Ashgate, 1999.

van Regemorter, Berthe. *Binding Structures in the Middle Ages: A Selection of Studies*. Translated and annotated by Jane Greenfield. Brussels: Bibliotheca Wittockiana, 1992.

CAROLINGIAN & EARLIER BINDINGS

Clarkson, Christopher. "Further Studies in Anglo-Saxon and Norman Bookbinding: Board Attachment Methods Re-examined" in *Roger Powell: The Compleat Binder; Liber Amicorum, Bibliologia 14*. ed. J.L. Sharpe. Turnhout: Brepols, 1996, 154-214.

Gullick, Michael. "Bookbindings" in *The Cambridge History of the Book in Britain Volume I: 400-1100*. Cambridge University Press, 2012, 294-309.

Szirmai, J.A. "Carolingian Bindings" in *The Archaeology of Medieval Bookbinding*. Aldershot: Ashgate, 1999, 99-139.

ROMANESQUE BINDINGS

Clarkson, Christopher. "A Hitherto Unrecorded English Romanesque Book Sewing Technique" in *Roger Powell: The Compleat Binder; Liber Amicorum, Bibliologia 14*. ed. J.L. Sharpe. Turnhout: Brepols, 1996, 215-239.

— "English Monastic Bookbinding in the Twelfth Century", in *Ancient and Medieval Book Materials and Techniques: Erice, 18-25 September 1992*. ed. Marilena Maniaci and Paola F. Munafò. Città del Vaticano: Biblioteca Apostolica Vaticana, 1993, 181-200.

Gullick, Michael. "Bookbindings" in *The Cambridge History of the Book in Britain Volume I: 400-1100*. Cambridge University Press, 2012, 294-309.

— "From Scribe to Binder: Quire Tackets in Twelfth Century European Manuscripts" in *Roger Powell: The Compleat Binder; Liber Amicorum, Bibliologia 14*. ed. J.L. Sharpe. Turnhout: Brepols, 1996, 240-259.

Pollard, Graham. "The construction of English 12th century bindings" in *The Library, Fifth Series, Vol 17, No. 1, March 1962*, 1-22.

Szirmai, J.A. "Romanesque bindings" in *The Archaeology of Medieval Bookbinding*. Aldershot: Ashgate, 1999, 140-172.

GOTHIC BINDINGS

- Bearman, Frederick. "The Origins and Significance of Two Late Medieval Textile Chemise Bookbindings in the Walters Art Gallery" in *Journal of the Walters Art Gallery, Vol 54, Essays in Honor of Lilian M. C. Randall*. The Walters Art Museum, 1996, 163-187.
- Gullick, Michael and Nicholas Hadgraft. "Bookbindings" in *Cambridge History of the Book in Britain, Volume II: 1100-1400*. Cambridge University Press, 2000, 95-109.
- Foot, M.M. "Bookbinding 1400-1557" in *The Cambridge History of the Book in Britain Volume III: 1400-1557*, Cambridge University Press, 2012, 109-127.
- Szirmai, J.A. "Gothic bindings" in *The Archaeology of Medieval Bookbinding*. Aldershot: Ashgate, 1999, 173-284.

LIMP BINDINGS

- Szirmai, J.A. "Limp bindings" in *The Archaeology of Medieval Bookbinding*. Aldershot: Ashgate, 1999, 285-319.

CHEMISE BINDINGS, GIRDLE BOOKS

- Bearman, Frederick. "The Origins and Significance of Two Late Medieval Textile Chemise Bookbindings in the Walters Art Gallery" in *Journal of the Walters Art Gallery, Vol 54, Essays in Honor of Lilian M. C. Randall*. The Walters Art Museum, 1996, 163-187.
- Greenfield, Jane. "Consolatione Philosophiae" in *The Yale University Library Gazette, Vol. 77, No. 1/2*. New Haven: Yale University, 2002, 91-93.
- van Leeuwen, Jan Storm. "The Well-Shirted Bookbinding: On Chemise Bindings and Hülle-neinbände," in *Theatrum Orbis Librorum: Liber Amicorum, Presented to Nico Israel on the Occasion of His Seventieth Birthday*. ed. T. Croiset van Uchelen et al. Utrecht: 1989, 277-305.

ENDBANDS

- Bibliothèque Nationale, Service de la conservation et de la restauration. *Les tranche-filles brodées: étude historique et technique*. Paris: Bibliothèque Nationale, 1989, 14-49.
- Gast, Monika. "A History of Endbands based on a study by Karl Jäckel" in *The New Bookbinder: Journal of Designer Bookbinders, Vol. 3*. London (?): Designer Bookbinders, 1983, 42-58.
- Giuffrida, B. "Book Conservation Workshop Manual, Part Three: Endbands" in *The New Bookbinder: Journal of Designer Bookbinders, Vol. 2*. London(?): Designer Bookbinders, 1982, 29-39.

BOOK STORAGE AND LIBRARY FURNITURE

- Streeter, Burnett Hillman. *The Chained Library. A Survey of Four Centuries in the Evolution of the English Library*. New York: Burt Franklin, 1970 (reprint).
- Smith, Janet Charlotte. "The Side Chambers of San Giovanni Evangelista in Ravenna: Church Libraries of the Fifth Century" in *Gesta*, Vol. 29, No. 1. University of Chicago Press on behalf of the International Center of Medieval Art, 1990, pp.86-9



*Special Collections Conservation
Preservation Department, Yale University Library*

February 2015

*Above image: A monk using a sewing frame. 12th century. Bamberg, Staatsbibliothek, MS Patr. 5, fol. IV.
Cover image: Beinecke Rare Book & Manuscript Library, Beinecke MS 866.*